

SINGAPORE CHINESE GIRLS' SCHOOL

PRELIMINARY EXAMINATION 2019

PRIMARY 6

MATHEMATICS
PAPER 1

BOOKLET A

Name : _____ ()

Class : Primary 6 SY / C / G / SE / P

20 August 2019

		Marks attained	Max Mark
Paper 1	Booklet A		20
	Booklet B		25
Paper 2			55
Total Marks			100

Parent's Signature

15 Questions
20 Marks

Total Time for Booklets A and B: 1 h

INSTRUCTIONS TO CANDIDATES

Do not open this booklet until you are told to do so.

Follow all instructions carefully.

Answer all questions.

You are not allowed to use a calculator

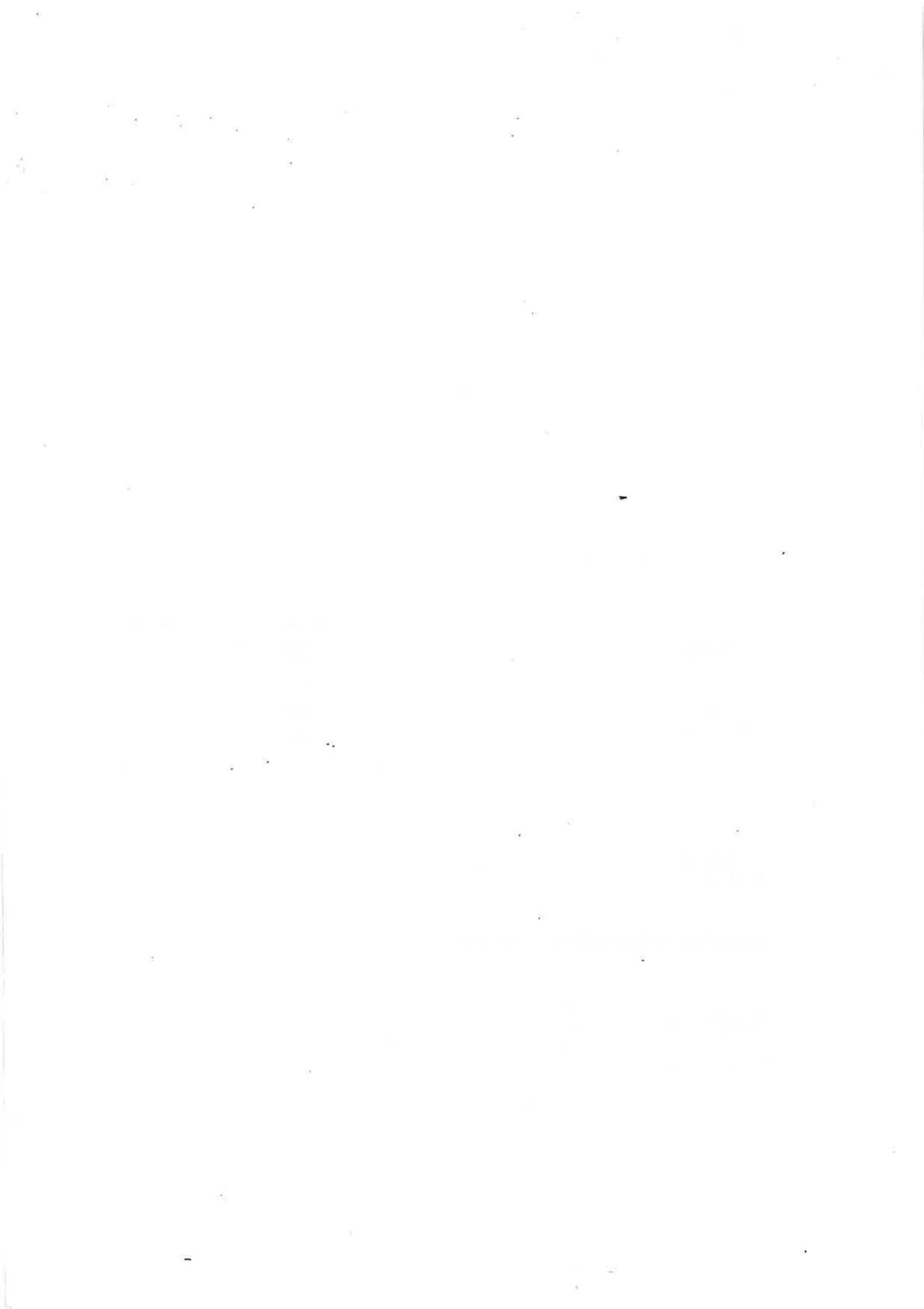

Booklet A

Questions 1 to 10 carry 1 mark each. Questions 11 to 15 carry 2 marks each.
For each question, four options are given. One of them is the correct answer.
Make your choice (1, 2, 3 or 4) and shade your answer on the Optical Answer Sheet.
(20 marks)

1. What does the digit 3 in 4.362 stand for?

- (1) 3 ones
- (2) 3 tenths
- (3) 3 hundredths
- (4) 3 thousandths

2. Express 10.85 km in metres.

- (1) 108.5 m
- (2) 1085 m
- (3) 10 850 m
- (4) 108 500 m

3. Which of the following, when rounded off to the nearest thousands, is **not** 27 000?

- (1) 26 749
- (2) 26 952
- (3) 27 308
- (4) 27 514

4. Which of the following statements is **true** about the parallelogram ABCD?

- (1) $\angle DAB + \angle BCD = 180^\circ$
- (2) AD is perpendicular to BC.
- (3) A parallelogram has a line of symmetry
- (4) $\angle ABC = \angle ADC$.

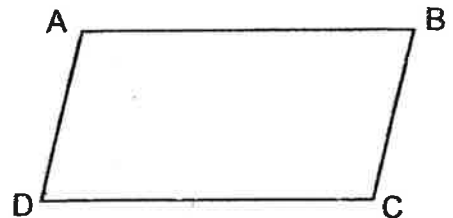

5. Which of the following fractions has the smallest value?

(1) $\frac{5}{11}$

(2) $\frac{4}{7}$

(3) $\frac{1}{2}$

(4) $\frac{7}{9}$

6. Find the value of $55 + \frac{5}{100} + \frac{5}{1000}$

(1) 55.505

(2) 55.55

(3) 55.05

(4) 55.055

7. Which of the following is **not** a net of a prism?

(1)

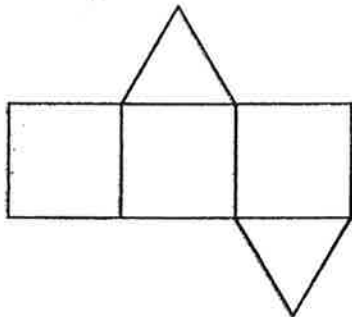

(2)

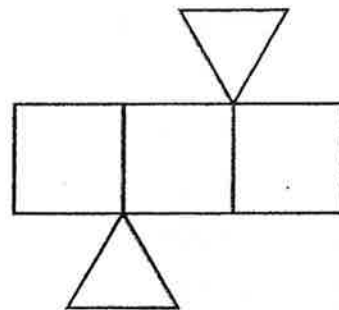

(3)

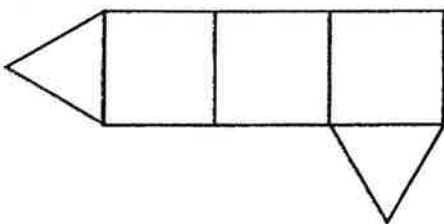

(4)

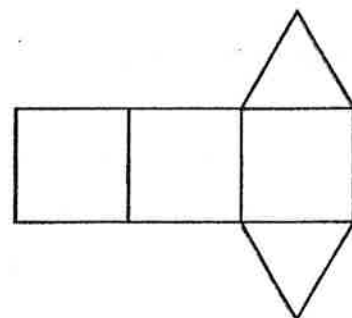

8. Which of the following letters has only **one** line of symmetry?

- (1) E
- (2) H
- (3) O
- (4) X



9. In the square grid below, A, B, C and D represent four landmarks in a town. In which direction is C from D?

- (1) N
- (2) W
- (3) NW
- (4) SE

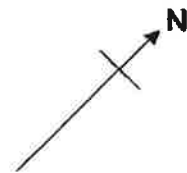
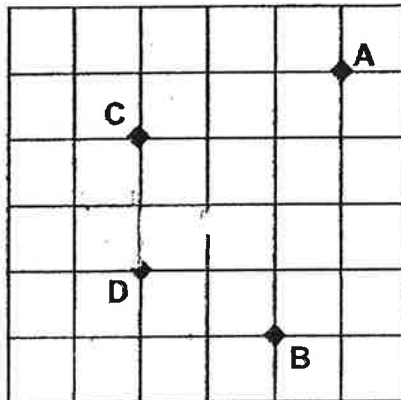

10. Nurul saved a total of \$3.00 in three days. Each day, she saved 30 cents more than the previous day. How much did she save on the second day?

- (1) \$1.00
- (2) \$0.70
- (3) \$1.10
- (4) \$0.80

11. The pie chart shows the favourite fruit of a group of children. 150 children like cherry and mango. How many more children prefer cherry to mango?

- (1) 90
- (2) 60
- (3) 30
- (4) 15

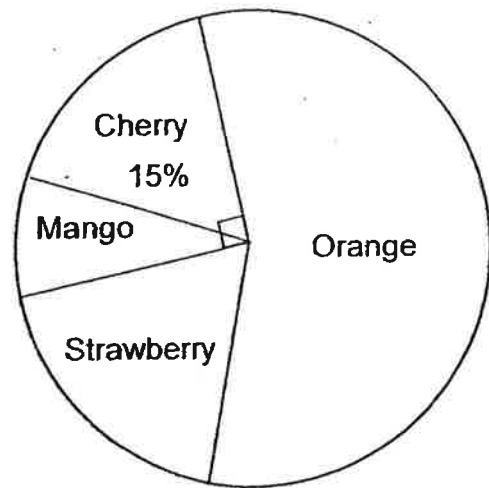

12. The figure below is made up of two identical quadrants and a square. What is the perimeter of the shaded part?

- (1) $(5\pi + 10)$ cm
- (2) $(5\pi + 20)$ cm
- (3) $(20\pi + 10)$ cm
- (4) $(20\pi + 20)$ cm

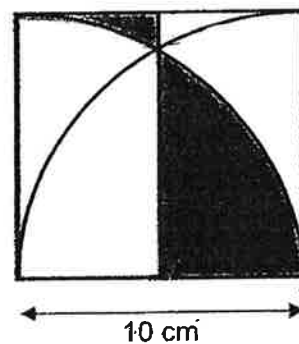

13. In the figure below, ABCD is a square. $\angle DAE = 39^\circ$ and $\angle AGD = 47^\circ$. Find $\angle AFD$.

- (1) 41°
- (2) 45°
- (3) 47°
- (4) 51°

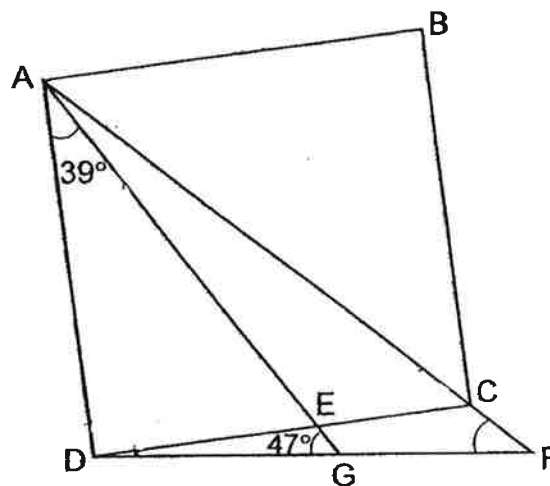

14. The table below shows the NAPFA test Awards of a group of students.

Award	Number of students
Gold	80
Silver	70
Bronze	40
Nil	?

$\frac{3}{4}$ of the students achieved at least a Silver award in the NAPFA test. How many students did not achieve any award?

- (1) 10
- (2) 30
- (3) 40
- (4) 50

15. A cyclist took $\frac{3}{10}$ h to cycle from his home to the park, 12 km away. When he left the park, he cycled along the same route and took 30 min to reach home. What was his average speed for the whole journey to and fro?

- (1) 15 km/h
- (2) 30 km/h
- (3) 48 km/h
- (4) 64 km/h

(Go on to Booklet B)

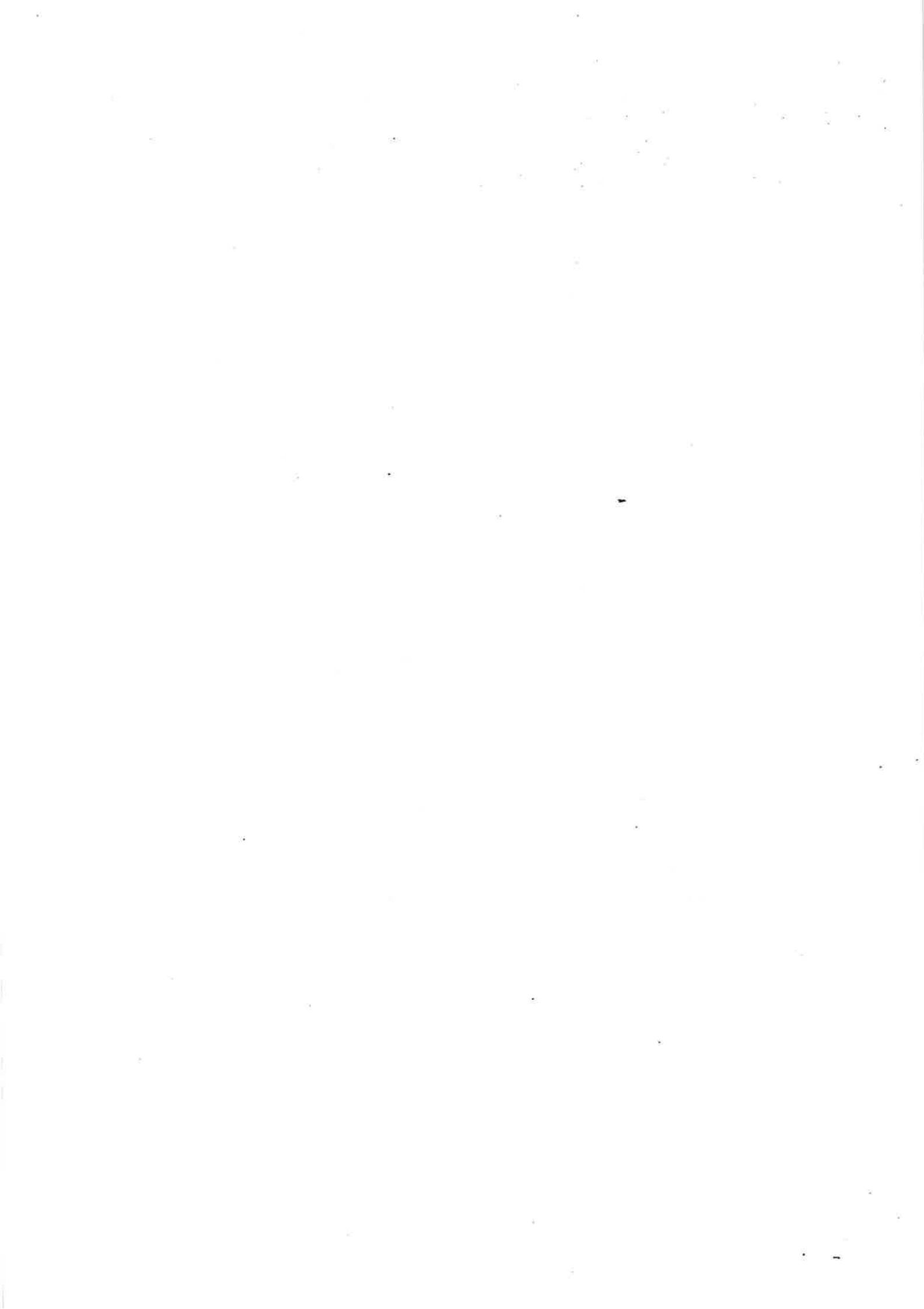

SINGAPORE CHINESE GIRLS' SCHOOL

PRELIMINARY EXAMINATION 2019

PRIMARY 6

**MATHEMATICS
PAPER 1**

BOOKLET B

Name : _____ ()

Class : Primary 6 SY / C / G / SE / P

20 August 2019

Paper 1	Mark attained	Max Mark
Booklet B		25

**15 Questions
25 Marks**

Total Time for Booklets A and B: 1 h

INSTRUCTIONS TO CANDIDATES

Do not open this booklet until you are told to do so.

Follow all instructions carefully.

Answer all questions.

You are **not allowed** to use a calculator



Booklet B

Do not write
in this
column

Questions 16 to 20 carry 1 mark each. Write your answers in the spaces provided.
For questions which require units, give your answers in the units stated. (5 marks)

16. Evaluate $\frac{2}{3} \times (48 - 30) + 28 \div 4$

Ans: _____

17. Find the value of $\frac{5}{6} \div 10$.

Ans: _____

18. What is the length of the paper clip?

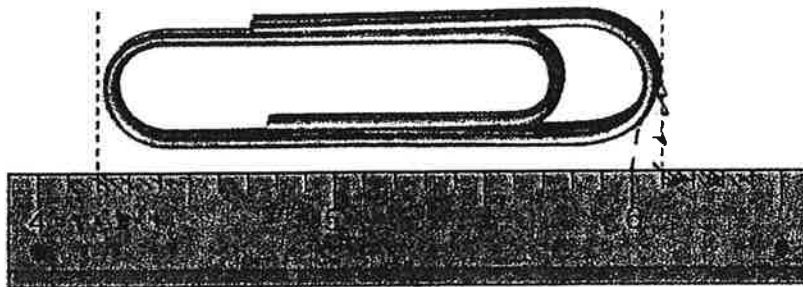

Ans: _____ cm

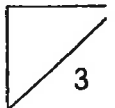

19. Express 0.429 as a percentage.

Do not write
in this
column

Ans: _____ %

20. Brandon used a piece of 68-cm wire to fold into a star, such that $AC = CE = EB = BD = DA$. What is the length of AC ?

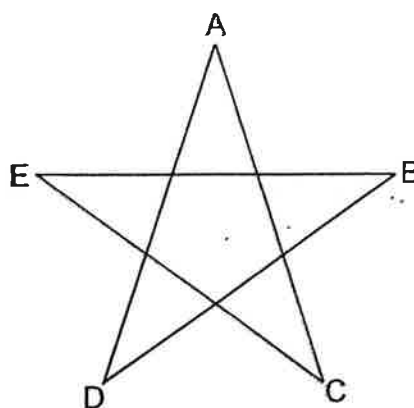

Ans: _____ cm

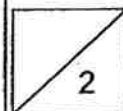

Questions 21 to 30 carry 2 marks each. Show your working clearly in the space for each question and write your answers in the space provided.
For questions which require units, give your answers in the units stated. (20 marks)

Do not write
in this
column

21. A triangle C is drawn by joining dots on the square grid with three straight lines.
- (a) In the same way, draw another triangle with twice the perimeter of C on the square grid. Label this triangle D.
- (b) What is the ratio of the area of C to the area of D?

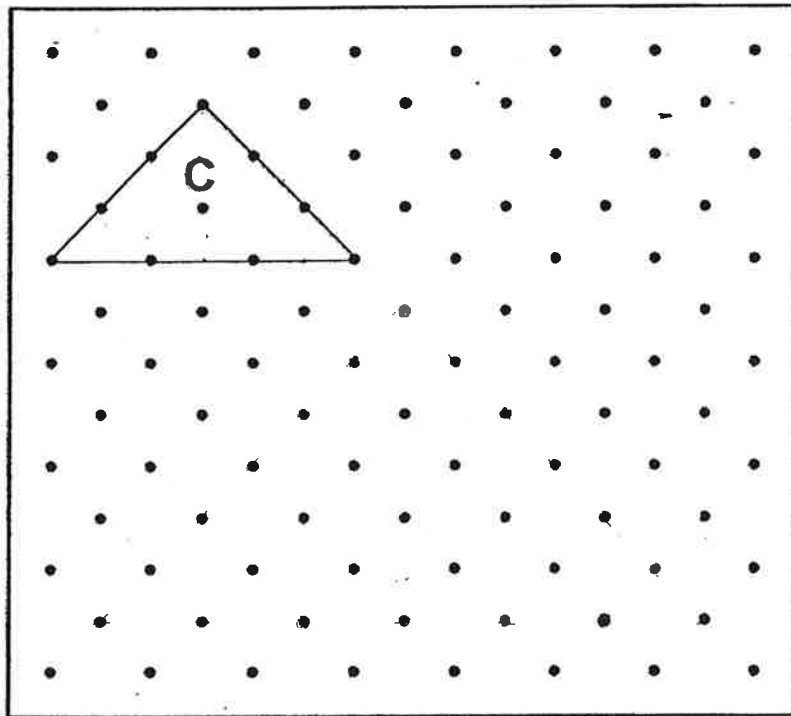

Ans: b) _____

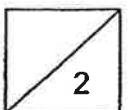

22. The figure below is made up of three 2-cm cubes. Find the total surface area of the figure.

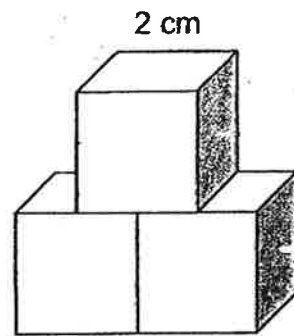

Do not write
in this
column

Ans: _____ cm²

23. Peggy saved $\frac{2}{7}$ of her salary and Gary saved $\frac{4}{9}$ of his salary. If they saved the same amount of money, what is the ratio of Peggy's salary to Gary's salary?

Ans: _____

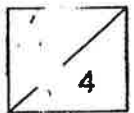

Use the information below to answer Questions 24 and 25.

Do not write
in this
column

The graph below shows the number of children who participated in an art competition in the respective years.

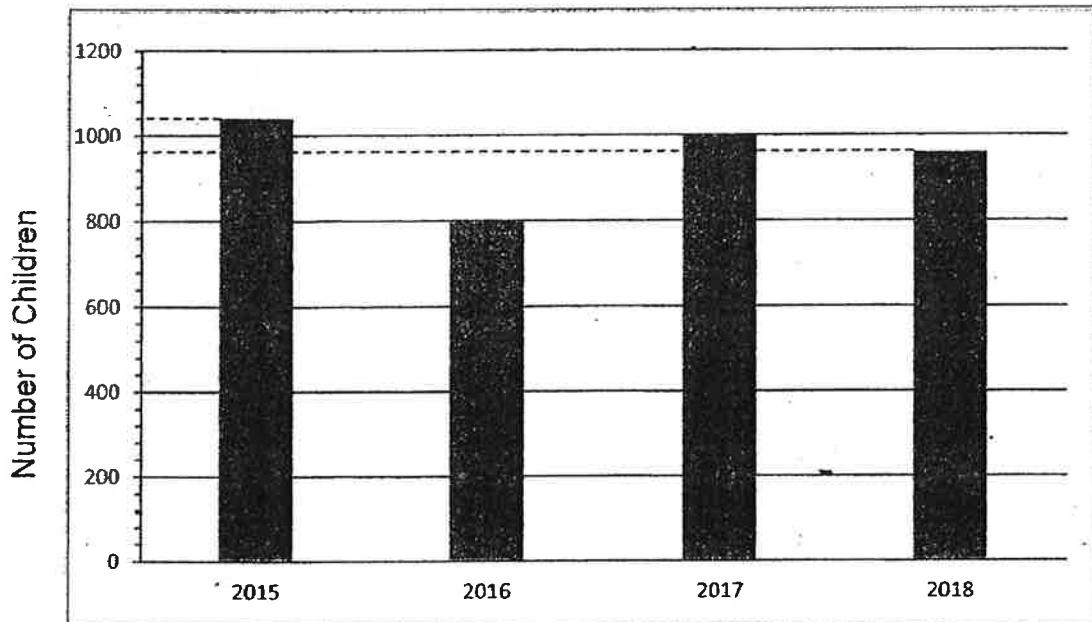

24. What is the percentage increase in the number of participants between the years 2016 and 2017?

Ans: _____ %

25. What is the average number of students who participated in the competition?

Ans: _____

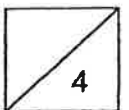

26. ABCD is a square with an area of 108 cm^2 . E is the midpoint of BC and F is the midpoint of AB. Find the shaded area.

Do not write
in this
column

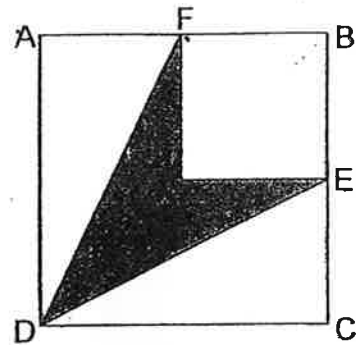

Ans: _____ cm^2

27. Sandra is p years old. Jay is 3 years older than her and 5 years younger than Erin. What is the total age of the three children?

Ans: _____

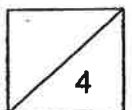

28. The table below shows the number of hours that a group of 20 children spent on screen time in a day.

Do not write
in this
column

Number of hours spent	0	2	3	4
Number of children	2	7	8	3

What is the average number of hours spent on screen time each day?

Ans: _____ hours

29. The following figure is made up of 4 identical rectangles and a shaded rectangle. The length of BC is 16 cm. If the area of the shaded part is 24 cm^2 , what is the length of EB?

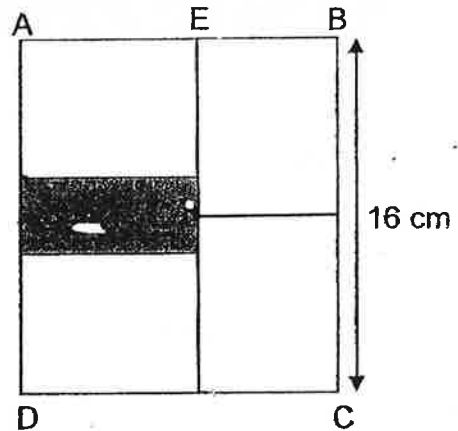

Ans: _____ cm

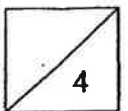

30. The figure below is not drawn to scale. It is made up of an isosceles triangle and a rhombus. $\angle MRN = 57^\circ$ and $\angle NPQ = 122^\circ$.

Do not write
in this
column

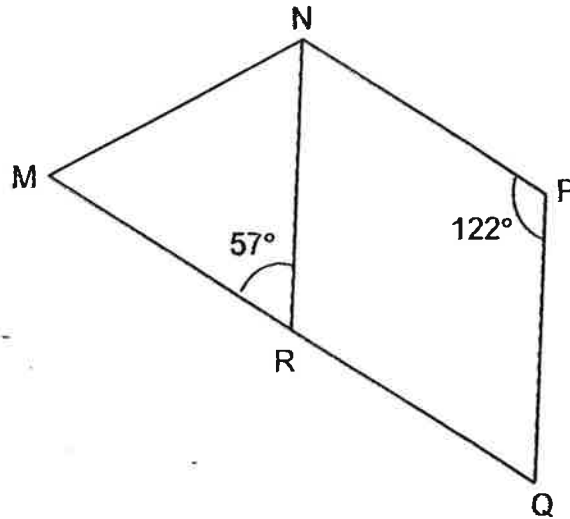

Each of the statements below is either true, false or not possible to tell from the information given. For each statement, put a tick (✓) to indicate your answer.

Statement	True	False	Not possible to tell
The lines MR and RN are equal in length.			
The figure MNPQR is a trapezium.			

End of Booklet B

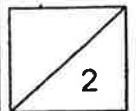

SINGAPORE CHINESE GIRLS' SCHOOL

PRELIMINARY EXAMINATION 2019

PRIMARY 6

MATHEMATICS

PAPER 2

Name : _____ ()

Class : Primary 6 SY / C / G / SE / P

20 August 2019

	Mark	Max Mark
Paper 2		55

Parent's Signature

17 Questions

55 Marks

Total Time for Paper 2: 1 h 30 min

INSTRUCTIONS TO CANDIDATES

Do not open this booklet until you are told to do so.

Follow all instructions carefully.

Answer all questions.

You are allowed to use the calculator

Questions 1 to 5 carry 2 marks each. Show your working clearly in the space below each question and write your answers in the spaces provided. For questions which require units, give your answers in the units stated. **(10 marks)**

Do not write in this column

- 1 Peter wanted to buy a bag but he only had $\frac{1}{5}$ of the money. After receiving \$12 from his father, he was still short of $\frac{1}{2}$ of the money. What is the price of the bag?

Ans: \$ _____

- 2 Alan, Ben and Carol had 18, 27 and 106 marbles respectively. Each of them bought an equal number of marbles, after which Carol had as many marbles as the total number that Alan and Ben had. How many marbles did each child buy?

Ans: _____

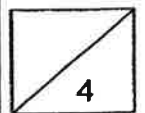

3. Roger saves \$y on Monday. Every day, he increases the amount saved by 100%. Find the total amount saved from Monday to Wednesday.

Do not write in
this column

Ans: \$ _____

-
4. A tin of paint weighed 10.5 kg when it was $\frac{1}{2}$ full. When it was $\frac{1}{3}$ full, it weighed 7.5 kg. What was the mass of the tin when it was empty?

Ans: _____ kg

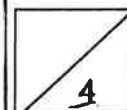

5. Mr Wong gave away 236 apples to a group of people. There were 10 more children than adults who received the apples. Each child received 2 apples while each adult received 4. How many adults received the apples?

Do not write in
this column.

Ans: _____

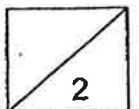

For questions 6 to 17, show your working clearly in the space below each question and write your answers in the spaces provided. The number of marks awarded is shown in brackets [] at the end of each question or part-question. **(45 marks)**

Do not write in this column

6. A notebook cost \$2. For every 4 notebooks bought, 1 was given free. Hoping to enjoy the promotion, Jane wanted to buy 18 notebooks but is short of \$3. How much money does she have?

Ans: _____ [3]

7. In the figure, JKLM is a square, $\angle MNK = 156^\circ$. Find $\angle JKN$.

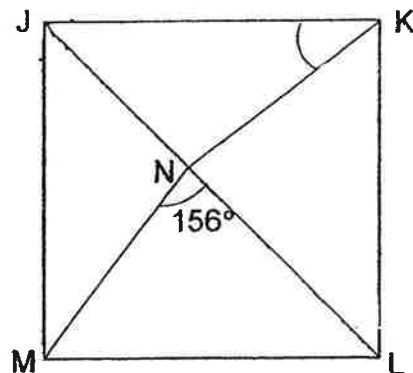

Ans: _____ [3]

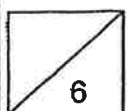

8. Town P and Town Q are 221 km apart. Laura left Town P for Town Q at 10.00 a.m., travelling at an average speed of 81 km/h. Mandy left Town Q for Town P at 11.00 a.m., travelling at an average speed of 94 km/h. What was the distance travelled by Laura when she passed Mandy?

Do not write in
this column

Ans: _____ [3]

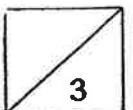

9. The figure below is made up of two semi-circles and two isosceles triangles. The diameter of the smaller semi-circle is 10 cm while the diameter of the bigger semi-circle is 15 cm.

Taking $\pi = 3.14$, find the area of the shaded part.

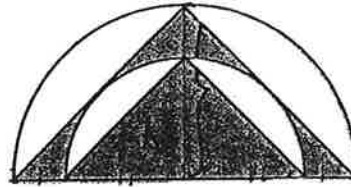

Do not write in
this column

Ans: _____ [3]

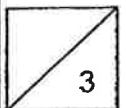

10. Figure A shows a sealed container partially filled with 48 cm^3 of water. The container is then placed lying on its back as shown in Figure B. What is the height of the water level in Figure B?

Do not write in this column

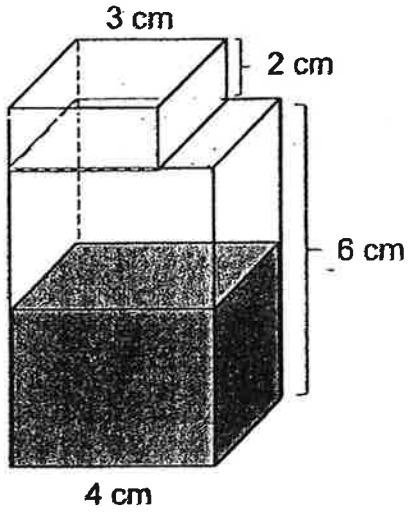

Figure A

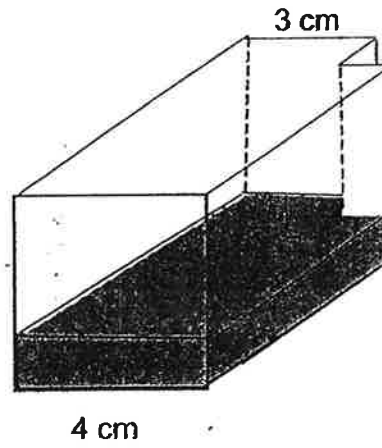
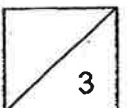

Figure B

Ans: _____ [3]



11. Mrs Teo paid \$122.40, after 15% discount, for petrol purchase at a petrol station. Petrol price before discount was \$2.25 per litre.

Do not write in this column

- (a) How many litres of petrol did Mrs Teo purchase?
- (b) Mrs Teo's car can travel 15.8 km with every litre of petrol. With the amount of petrol that she had purchased, what is the maximum distance that her car can travel?

Ans: a) _____ [2]

b) _____ [2]

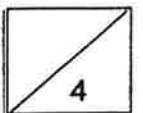

12. The figure below is not drawn to scale. ABCD is a rhombus and BCE is an equilateral triangle. $\angle ADC = 64^\circ$. Find $\angle CAE$.

Do not write in this column

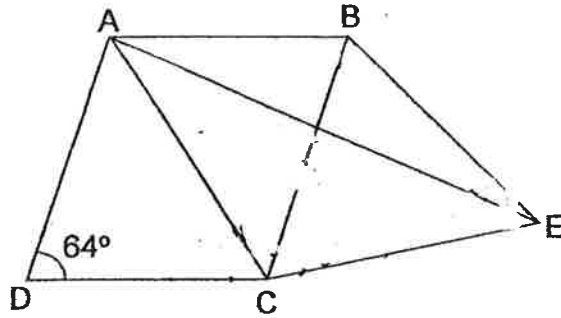

Ans: _____ [4]

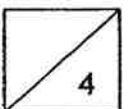

13. Pauline had some money. She spent $\frac{1}{4}$ of it on a book and received another \$33 from her mother. With what she had left, she spent 60% of it on a bag and had \$24 left. How much money did Pauline have at first?

Do not write in
this column

Ans: _____ [4]

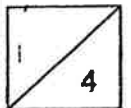

14. A piece of square paper of sides 12 cm is cut into 4 parts W, X, Y and Z along the dotted lines as shown below. The 4 pieces of cutouts can be rearranged to form a rectangle by shifting Z and W.

- (a) What is the area of the rectangle?
- (b) Find the perimeter of the rectangle that is formed.

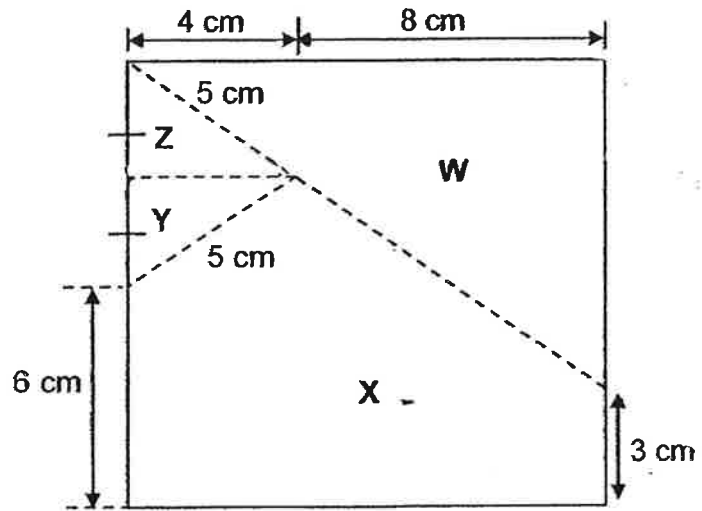

Ans: a) _____ [2]

b) _____ [2]

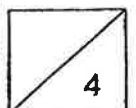

15. The table shows the overseas postage rate for bulky items.

Destinations	1 st 5kg	Additional kg or part thereof
Australia	\$40	\$7
Europe	\$50	\$9
Korea	\$30	\$5

Do not write in this column

Timothy sent a parcel to each of his friends in Australia, Europe and Korea as shown below. Timothy paid a total of \$146 for the postage of the three parcels.

He paid \$16 more for the postage to Australia than to Korea.

What was the additional mass that Timothy was charged for the postage to Australia?



To Europe
Parcel weighs less than 5 kg



To Korea
Parcel weighs more than 5 kg



To Australia
Parcel weighs more than 5 kg

Ans: _____ [4]

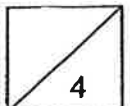

16. The diagram shows three banners hung from a beam to the floor. The total length of the three banners is 8.7 m. Banner B is 4.2 m long.

Banner A and Banner C are each extended with a rope, after which each extended banner reaches the floor like Banner B. The longer rope is twice the length of the shorter rope.

What is the length of Banner C?

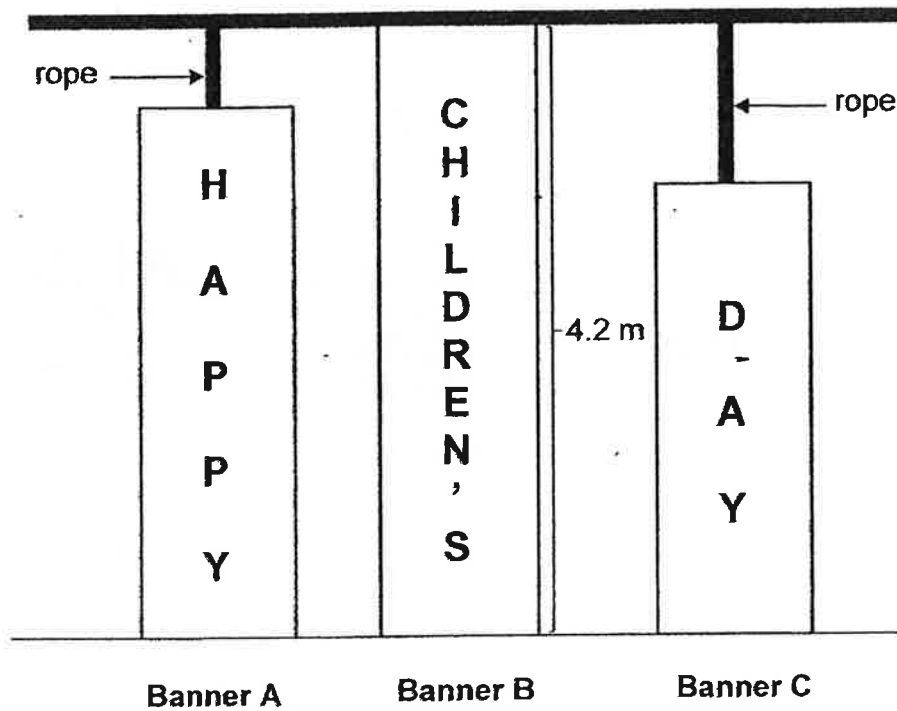

Do not write
this column

Ans: _____ [5]

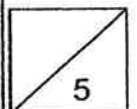

17. Study the pattern carefully and answer the questions that follow.

Do not write in this column

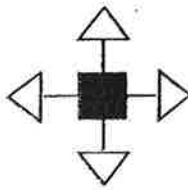

Pattern 1

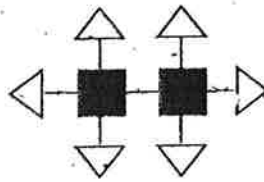

Pattern 2

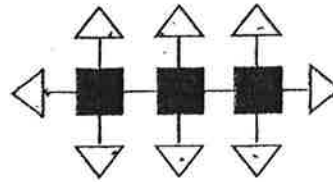

Pattern 3

Pattern number	1	2	3	...	25
Number of triangles	4	6	8	...	
Number of straight lines	4	7	10	...	

- (a) How many triangles are needed to form Pattern 25?
- (b) Which pattern is made up of 217 straight lines?
- (c) What is the total number of triangles and squares needed to form Pattern 48?

Ans: a) _____ [1]

b) _____ [2]

c) _____ [2]

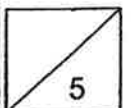

End of Paper

ANSWER KEY

YEAR : 2019
LEVEL : PRIMARY 6
SCHOOL : Singapore Chinese Girls' School
SUBJECT : Mathematics
TYPE : Preliminary



Paper 1 Booklet A

Q1	Q2	Q3	Q4	Q5	Q6	Q7	Q8	Q9	Q10
2	3	4	4	1	4	3	1	3	1
Q11	Q12	Q13	Q14	Q15					
3	2	1	1	2					

Paper 1 Booklet B

- Q16. 19
Q17. $\frac{1}{12}$
Q18. 1.9
Q19. 42.9
Q20. 13.6
Q21. 1:4 (b)
Q22. 56
Q23. 14:9
Q24. 25
Q25. 950
Q26. 27
Q27. $(3p + 11)$
Q28. 2.5
Q29. 6.5
Q30. Not possible to tell, False

Paper 2

- Q1. \$40

Q2. 61

Q3. 7y

Q4. $10.5 - 9 = 1.5$

Q5. $2 + 4 = 6$
 $216/6 = 36$

Q6. $3 \times 4 = 12$
 $12 \times \$2 = \24
 $\$24 + 3 = \27

Q7. $90 - 57 = 33$

Q8. 145.8km

Q9. $10 \times 5 \times 0.5 = 25$

$$5 \times 5 \times 3.14 \times 0.5 = 39.25$$

$$0.5 \times 15 \times 7.5 = 56.25$$

$$56.25 - 39.25 = 17$$

$$17 + 25 = 42$$

Q10. 1.6cm

Q11.

a) $144/2.25 = 64L$

b) $64 \times 15.8 = 1011.2km$

Q12. $56/2 = 28$

$$58 - 28 = 30$$

Q13. $3u = 27$

$$1u = 9$$

$$9 \times 4 = \$36$$

Q14.

a) $16 \times 9 = 144$

b) $16 \times 2 = 32$

$$9 \times 2 = 18$$

$$32 + 18 = 50cm$$

Q15. Not solvable.

Q16. $3u = 3.9$

$$1u = 1.3$$

$$4.5 - 1.3 = 3.2$$

$$3.2/2 = 1.6m$$

Q17.

a) $25 + 1 = 26$

$$26 \times 2 = 52$$

b) $(217 - 1)/2 = 72$

c) $(48 + 1) \times 2 = 98$

$$98 + 48 = 146$$



3
7/12