



**RAFFLES GIRLS' PRIMARY SCHOOL  
PRELIMINARY EXAMINATION  
MATHEMATICS (PAPER 1)  
PRIMARY 6**

Name: \_\_\_\_\_ (    )

Form Class: P6 \_\_\_\_\_

Math Teacher : \_\_\_\_\_

Date: 21 Aug 2019

Duration: 1 hour

<b>Your Paper 1 Score (Out of 45 marks)</b>	
<b>Your Paper 2 Score (Out of 55 marks)</b>	
<b>Your Total Score (Out of 100 marks)</b>	
<b>Parent's Signature</b>	

**INSTRUCTIONS TO CANDIDATES**

1. Do not turn over this page until you are told to do so.
2. Follow all instructions carefully.
3. Answer **ALL** questions and show all working clearly.
4. **NO** calculator is allowed for this paper.

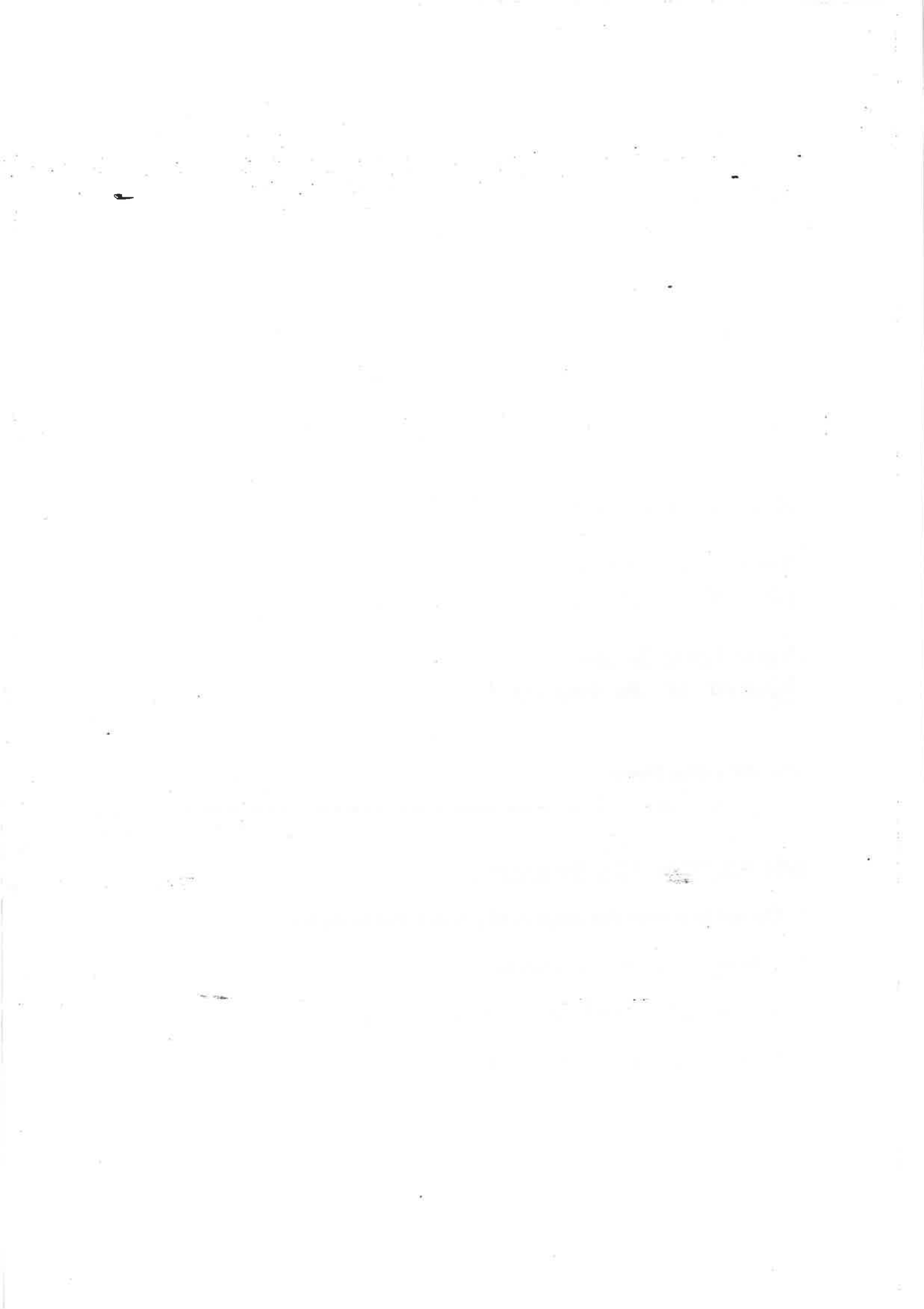

Questions 1 to 10 carry 1 mark each. Questions 11 to 15 carry 2 marks each.  
 For each question, four options are given. One of them is the correct answer.  
 Make your choice (1, 2, 3 or 4). Shade your answer (1, 2, 3 or 4) on the OAS provided.  
 All diagrams are not drawn to scale. (20 marks)

1.

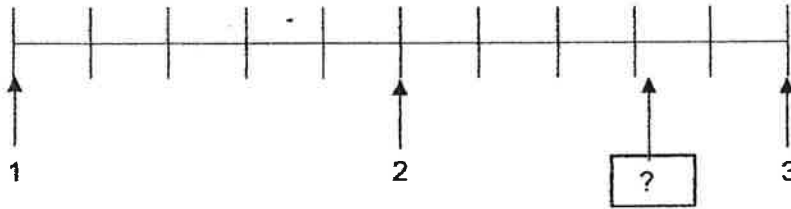

What is a possible number in the box?

- (1) 2.35
- (2) 2.55
- (3) 2.63
- (4) 2.75

2. What is the length of the spoon?

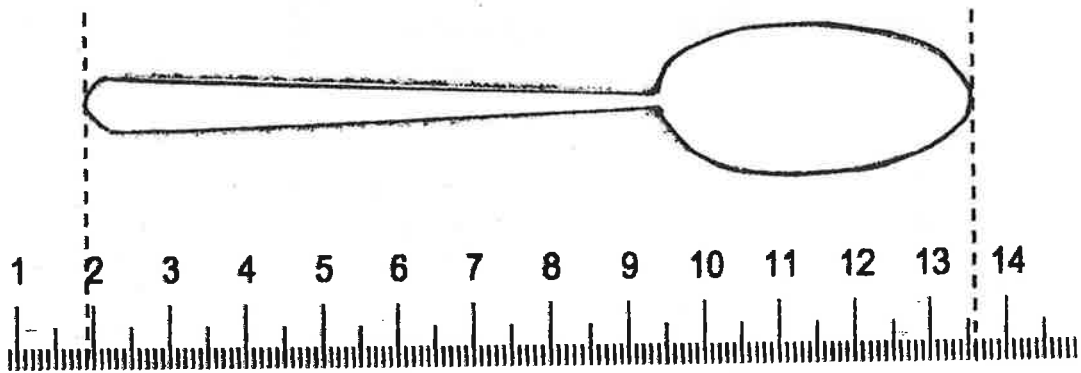

- (1) 1.9 cm
- (2) 11.7 cm
- (3) 12.7 cm
- (4) 13.6 cm

3. Which digit in 107 438 is in the ten thousands place?

(1) 1

(2) 0

(3) 3

(4) 4

4. Round 10 989 to the nearest hundred.

(1) 10 900

(2) 10 990

(3) 11 000

(4) 11 090

5. Alex, Ben, Carl and Den shared a cake. Alex ate  $\frac{1}{5}$  of the cake. Ben ate  $\frac{3}{10}$  of the cake. Carl ate  $\frac{1}{3}$  of the cake while Dan ate the remaining cake. Who ate the largest portion of the cake?

(1) Alex

(2) Ben

(3) Carl

(4) Dan

6. Find the area of the shaded triangle.

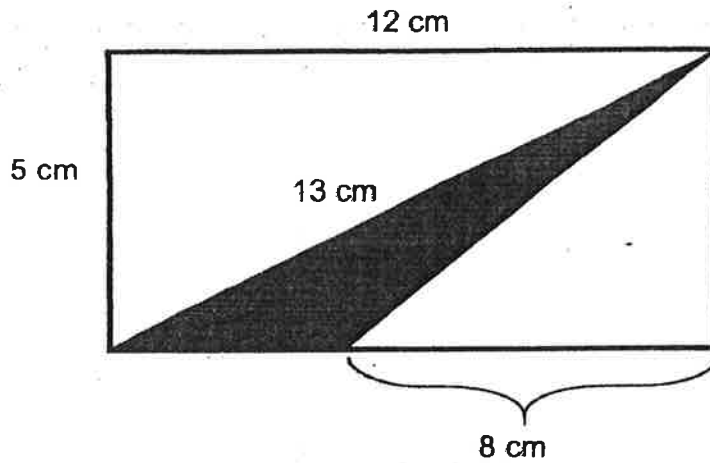

- (1)  $10 \text{ cm}^2$   
(2)  $20 \text{ cm}^2$   
(3)  $30 \text{ cm}^2$   
(4)  $32.5 \text{ cm}^2$
7. Mary and Sally had an equal number of stamps. Mary gave  $\frac{3}{7}$  of her stamps to Sally. What was the ratio of Sally's number of stamps to Mary's number of stamps in the end?
- (1) 10 : 7  
(2) 10 : 3  
(3) 7 : 3  
(4) 5 : 2

8. The solid has 4 triangular faces.

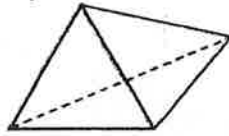

Which of the following nets can be folded to form this solid?

(A)

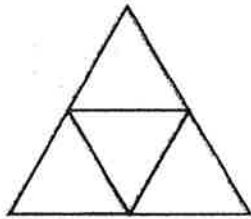

(B)

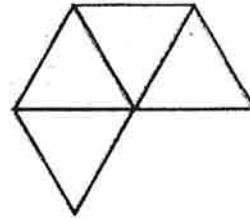

(C)

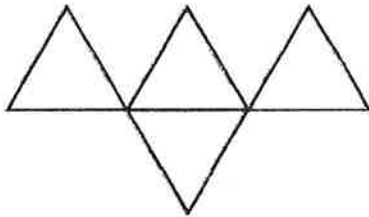

(D)

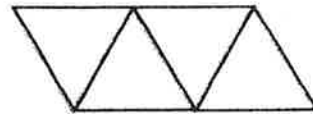

- (1) A and B only
- (2) B and C only
- (3) A and D only
- (4) B and D only

9. The table shows the number of toys produced at a factory from Monday to Saturday.

Day	Number of toys produced
Monday to Friday	$3k$ per day
Saturday	$4k - 5$

What was the total number of toys produced from Monday to Saturday?  
Express your answer in terms of  $k$  in the simplest form.

- (1)  $7k - 5$
- (2)  $15k$
- (3)  $19k$
- (4)  $19k - 5$

- 10.

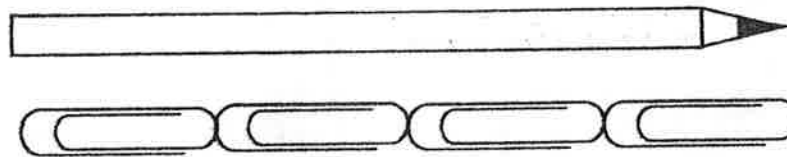

The length of 1 paper clip is 0.018 m. What is the length of the pencil?

- (1) 0.072 cm
- (2) 0.72 cm
- (3) 7.2 cm
- (4) 72 cm

11. In the figure, AOB and COD are straight lines.  $\angle COB = 135^\circ$  and  $\angle EOD = 75^\circ$ . Find  $\angle EOB$ .

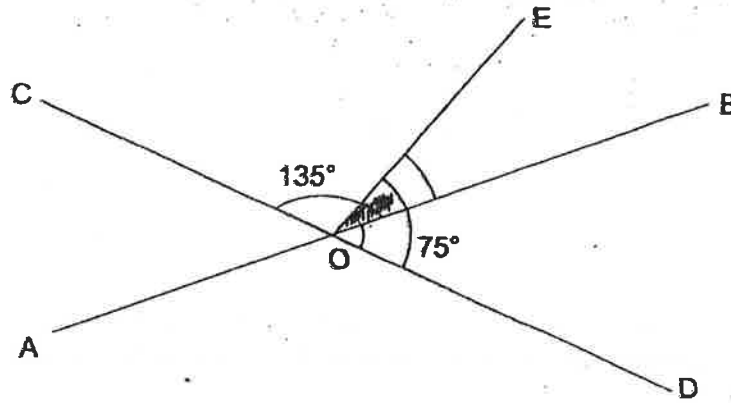

- (1)  $30^\circ$   
(2)  $45^\circ$   
(3)  $90^\circ$   
(4)  $105^\circ$
12. What is the total volume when the 6-cm metal cube is placed in the container?

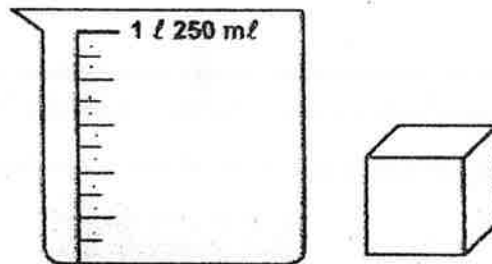

- (1)  $216 \text{ cm}^3$   
(2)  $375 \text{ cm}^3$   
(3)  $516 \text{ cm}^3$   
(4)  $591 \text{ cm}^3$



13. 30% of Tom's savings is equal to 25% of Mary's savings. What percentage of Tom's savings is Mary's savings?

(1)  $33\frac{1}{3}\%$

(2)  $83\frac{1}{3}\%$

(3) 120%

(4) 300%

14. The table shows the exchange rate for Singapore dollar and US dollar.

<b>1 Singapore dollar (SGD) = 0.70 US dollar (USD)</b>
--

How many Singapore dollars will I need to exchange for 1400 US dollar?

(1) 700 SGD

(2) 980 SGD

(3) 1400.30 SGD

(4) 2000 SGD

15. A box can fit exactly 8 large cubes, 64 medium cubes, or 512 small cubes. 3 large cubes, 32 medium cubes and some small cubes are put into such a box. What is the greatest possible number of small cubes that can fit into the box?

(1) 64

(2) 128

(3) 192

(4) 256

Questions 16 to 20 carry 1 mark each. Write your answers in the spaces provided. For questions which require units, give your answers in the units stated. All diagrams are not drawn to scale. (5 marks)

---

16. What is the answer in the box?

$$10\frac{5}{7} = \frac{56}{7} + \boxed{\phantom{00}}$$

Leave your answer as an improper fraction.

Ans: \_\_\_\_\_

17. Evaluate  $48 \times (8 - 4 \times 2)$ .

Ans: \_\_\_\_\_

18. When it is 10 a.m. in Singapore, it is 4 a.m. in South Africa on the same day. What time would it be in Singapore when it is 11.30 a.m. in South Africa? Give your time in 24-hour clock.

Ans: \_\_\_\_\_

19. A number is 0.50 when rounded to the nearest hundredth. What is the smallest possible number?

Ans: \_\_\_\_\_

20. Find the value when 1.099 is subtracted from 3.

Ans: \_\_\_\_\_

Questions 21 to 30 carry 2 marks each. Show your working clearly in the space provided for each question and write your answers in the spaces provided. For questions which require units, give your answers in the units stated. All diagrams are not drawn to scale. (20 marks)

---

21. What is the answer in the box?

$$24 \times 189 = 24 \times 140 + 24 \times$$

Ans: \_\_\_\_\_

22. A painter has 2 ℓ of red paint. He used  $\frac{1}{5}$  of it to mix with  $\frac{2}{3}$  ℓ of blue paint to get some purple paint. How much purple paint did he get?

Ans: \_\_\_\_\_ ℓ

23. Mr Tan deposited \$4000 in a fixed deposit account at ABC Bank at an interest rate of 1.5% per year. What was the amount of the interest earned in one year?

Ans: \$ \_\_\_\_\_

24. Muthu had  $9p$  sweets. He gave 5 sweets to each of his three friends and packed the remaining sweets equally into 3 packets. How many sweets were there in each packet? Give your answer in terms of  $p$  in the simplest form.

Ans: \_\_\_\_\_

25. Randy has 4 boxes of marbles. The number of marbles in each of the boxes is shown in the table.

Box	Number
A	27
B	19
C	25
D	26

Which box should he remove so that the average number of the marbles in the remaining boxes is 24?

Ans: Box \_\_\_\_\_

26. Find the perimeter of the figure.

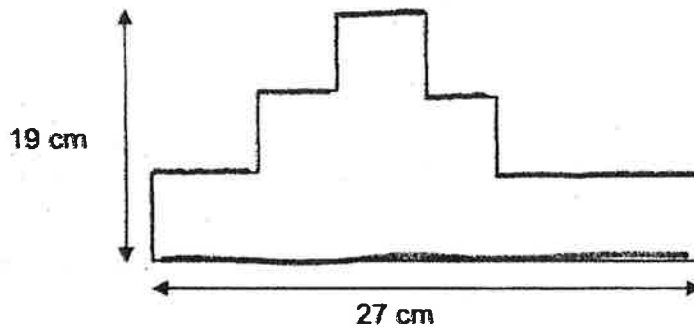

Ans: \_\_\_\_\_ cm

27. In a 4 by 100 m relay, Rani completed the first 100 m in 10 s, Eunice completed the second 100 m in 15 s, Joyce completed the third 100 m in 13 s and Siti completed the last 100 m in 12 s. What was the average speed of the 4 children for the relay?

Ans: \_\_\_\_\_ m/s

28. A group of children was asked to name their favourite flavour of ice-cream. The pie chart shows their preference.

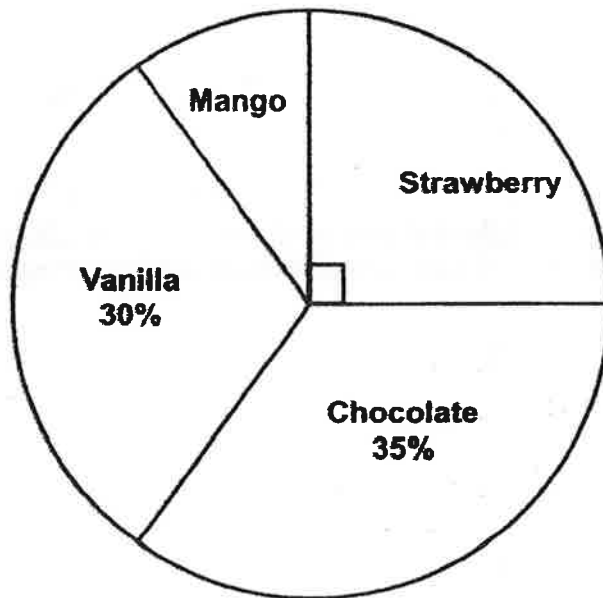

The number of children who liked chocolate and strawberry ice-cream was 42 more than the number of children who liked vanilla ice-cream. How many children liked mango ice-cream?

Ans: \_\_\_\_\_

29. In the figure, ABC is an isosceles triangle with  $BC = BA$ . BE is a straight line.  $\angle DCE = 117^\circ$ . Find  $\angle ABD$ .

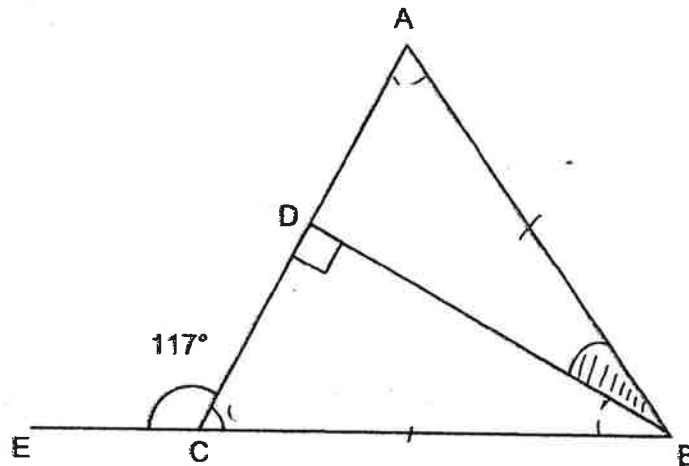

Ans: \_\_\_\_\_°

30. The number of stickers Kevin had was  $\frac{1}{4}$  more than the number of stickers John had. After Kevin gave 96 stickers to John, John had twice as many stickers as Kevin. How many stickers did John have at the end?

Ans: \_\_\_\_\_

**End of Paper**

☺ Please check your work carefully ☺





**RAFFLES GIRLS' PRIMARY SCHOOL  
PRELIMINARY EXAMINATION  
MATHEMATICS (PAPER 2)  
PRIMARY 6**

Name: \_\_\_\_\_ ( )

Form class: P6 \_\_\_\_\_

Math Teacher: \_\_\_\_\_

Date: 21 Aug 2019

Duration: 1 h 30 min

**INSTRUCTIONS TO CANDIDATES**

1. Do not turn over this page until you are told to do so.
2. Follow all instructions carefully.
3. Answer **ALL** questions and show all working clearly.
4. The use of calculator is allowed for this paper.

Questions 1 to 5 carry 2 marks each. Show your working clearly in the space provided for each question and write your answers in the spaces provided.  
 For questions which require units, give your answers in the units stated.  
 All diagrams are not drawn to scale. (10 marks)

1. John had a collection of local and foreign stamps. The ratio of the number of local stamps to the number of foreign stamps he had at first was 7 : 3. After giving away 46 foreign stamps, the ratio of the number of local stamps to the number of foreign stamps became 5 : 2. How many foreign stamps did John have in the end?

Ans: \_\_\_\_\_

2. In the figure, ABC is an isosceles triangle with  $AC = AB$ ,  $\angle ABD = 34^\circ$ .  $AD = AE$  with  $\angle ADE = 48^\circ$ . Find  $\angle CAD$ .

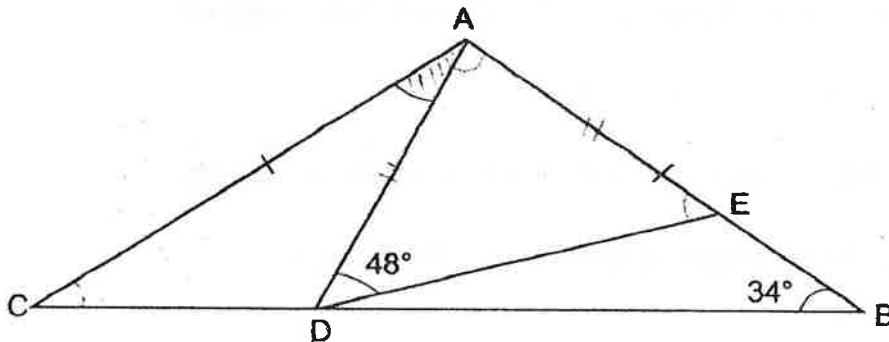

Ans: \_\_\_\_\_ °

3. A survey was conducted on the number of children in each household within a block of flats. The pie chart shows the results of the survey. AB is a straight line.

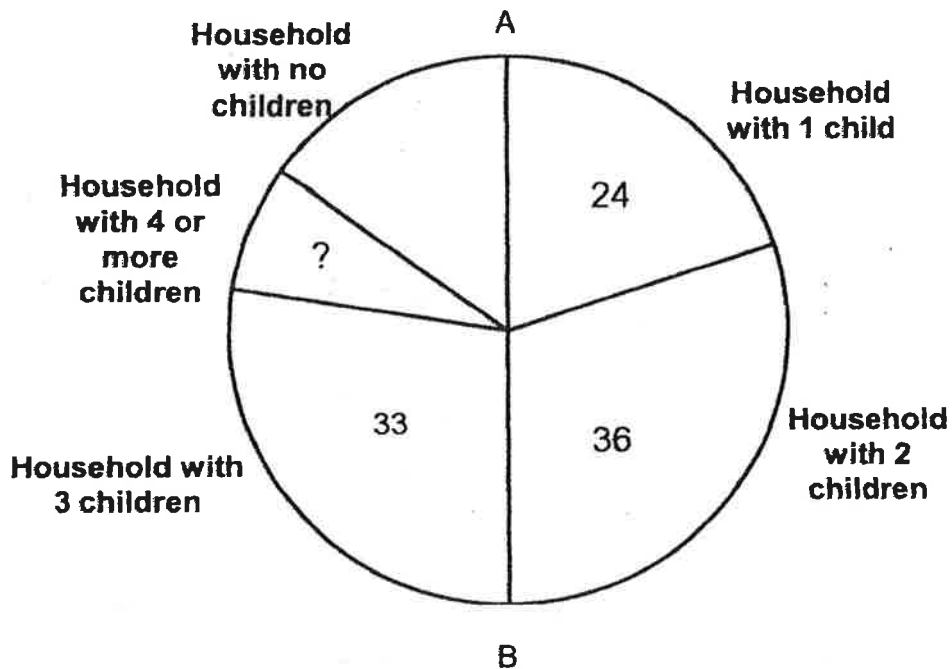

The number of household with 2 children was twice the number of household with no children. Express the number of household with 4 or more children as a fraction of the total number of household. Give your answer in the simplest form.

Ans : \_\_\_\_\_

4. Terence had a length of wire. He used the wire to make the triangle as shown.

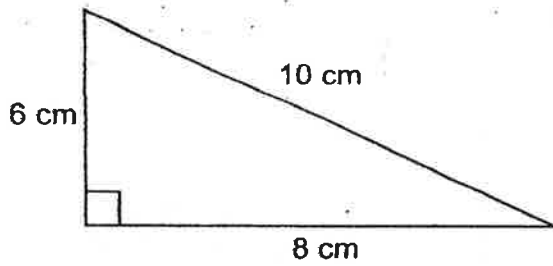

With the same wire, he used the entire length to make a square. What was the percentage increase in the area of the square compared to the area of triangle?

Ans : \_\_\_\_\_ %

5. The figure below is a triangle with sides A, B and C.

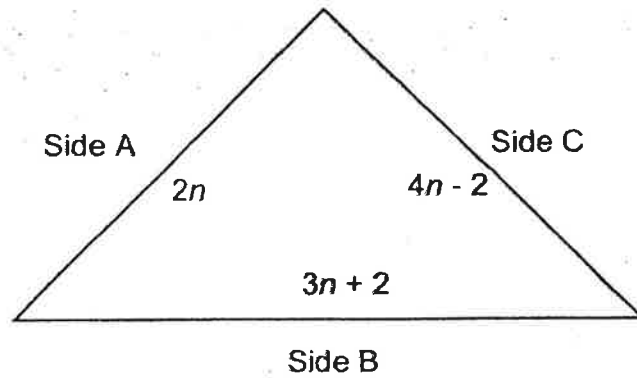

Each of the statements below is either true, false or not possible to tell from the information given. For each statement, put a tick(✓) to indicate your answer.

Statement	True	False	Not possible to tell
a) The length of side B is longer than the length of side A.			
b) The figure is an isosceles triangle as length of side A is equal to length of side C.			
c) The perimeter of the triangle is $(9n + 4)$ unit.			

For questions 6 to 17, show your working clearly in the space provided for each question and write your answers in the spaces provided. The number of marks available is shown in the brackets [ ] at the end of each question or part-question. All diagrams are not drawn to scale. (45 marks)

---

6.

$$\begin{array}{ccccccc} \triangle & + & \triangle & + & \triangle & + & \square & = & 81.76 \\ \square & + & \square & + & \triangle & & & = & 38.56 \end{array}$$

Find the value of 

Ans : \_\_\_\_\_ [3]

7. Ella and May had \$358 altogether. Ella and Kevin had \$698 altogether. Kevin had 5 times as much money as May. How much did Ella have at first?

Ans : \_\_\_\_\_ [3]

8. In the figure, ABCD is a square and EFGC is a trapezium.  $CE = BE$ ,  $\angle EFG = 110^\circ$  and  $\angle DCG = 230^\circ$ .

(a) Find  $\angle FGC$ .

(b) Find  $\angle CBE$ .

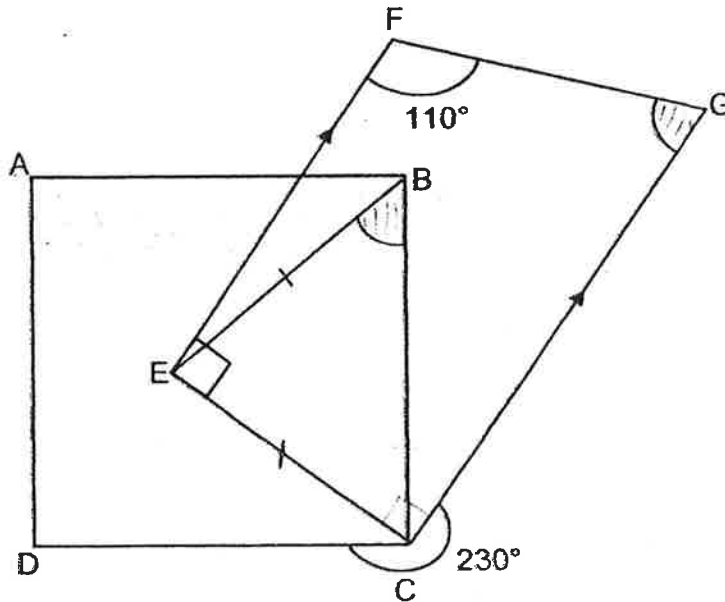

Ans: (a) \_\_\_\_\_ [1]

(b) \_\_\_\_\_ [2]

9. The figure is made up of a circle and three equilateral triangles of side 18 cm. Find the perimeter of the shaded parts. Take  $\pi = 3.14$ .

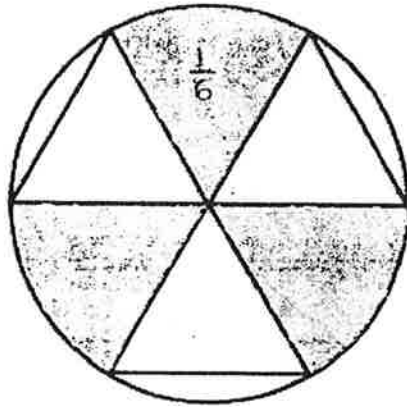

Ans : \_\_\_\_\_ [3]



10. Valerie had 40% more books than Isabelle. After Valerie bought some books, her number of books increased by 25%. Isabelle gave away 25% of her books. In the end, both the girls had 750 books altogether. How many books did Valerie have at first?

Ans : \_\_\_\_\_ [3]

11. The bar graph shows the sales of four food items at a fun fair.

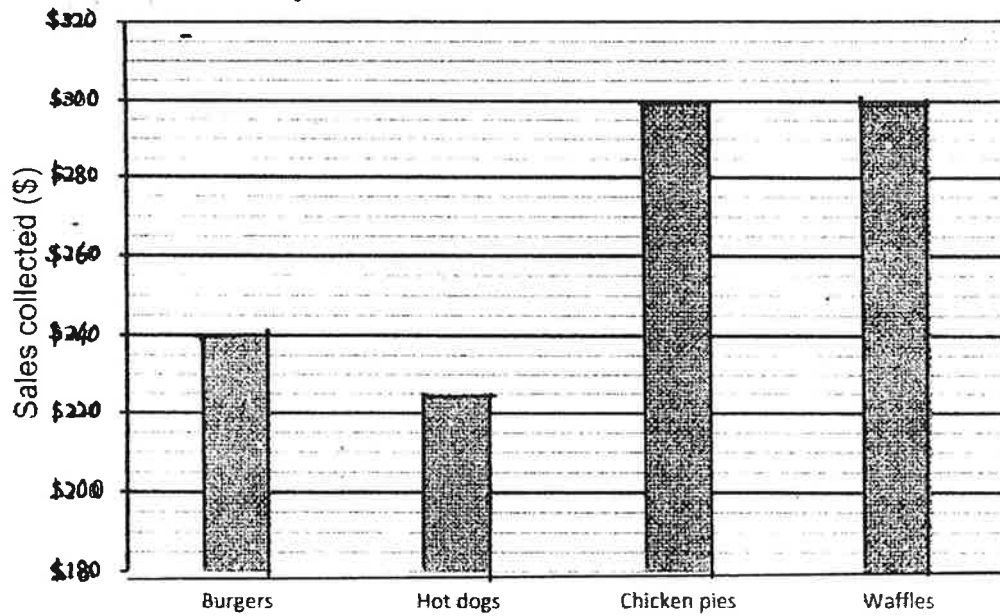

The table shows the prices of the food items.

Type of food items	Price per item
Burger	\$5
Hot dog	\$3
Chicken pie	\$4
Waffles	\$3

- (a) The quantity for two of the food items sold was the same. Which were the two food items?
- (b) What percentage of the food items sold were burgers?  
Leave your answer to the nearest 1 decimal place.

Ans: (a) \_\_\_\_\_ and \_\_\_\_\_ [2]

(b) \_\_\_\_\_ [2]

12. The table shows the charges for electricity consumption by ABC company.

Usage in kilowatts (kW)	Charges per kW
First 50 kW	\$0.55
Next 100 kW	\$0.72
Every additional kW and thereafter	\$0.88

- (a) Mrs Tan's family used 50 kW of electricity in July. How much did her family pay for their electricity consumption?
- (b) Mr Lee spent \$129.42 on electricity consumption in August. How many kilowatts of electricity did his family consume?

Ans: a) \_\_\_\_\_ [1]

b) \_\_\_\_\_ [3]

13. In the figure,  $ABC$  and  $BDC$  are triangles and  $BECF$  is a parallelogram.  $FH$  is a straight line,  $\angle GCH = 198^\circ$ ,  $\angle BEC = 104^\circ$ ,  $\angle BAC = 50^\circ$  and  $\angle ABE = 25^\circ$ .

(a) Find  $\angle DGB$ .

(b) Find  $\angle ACE$ .

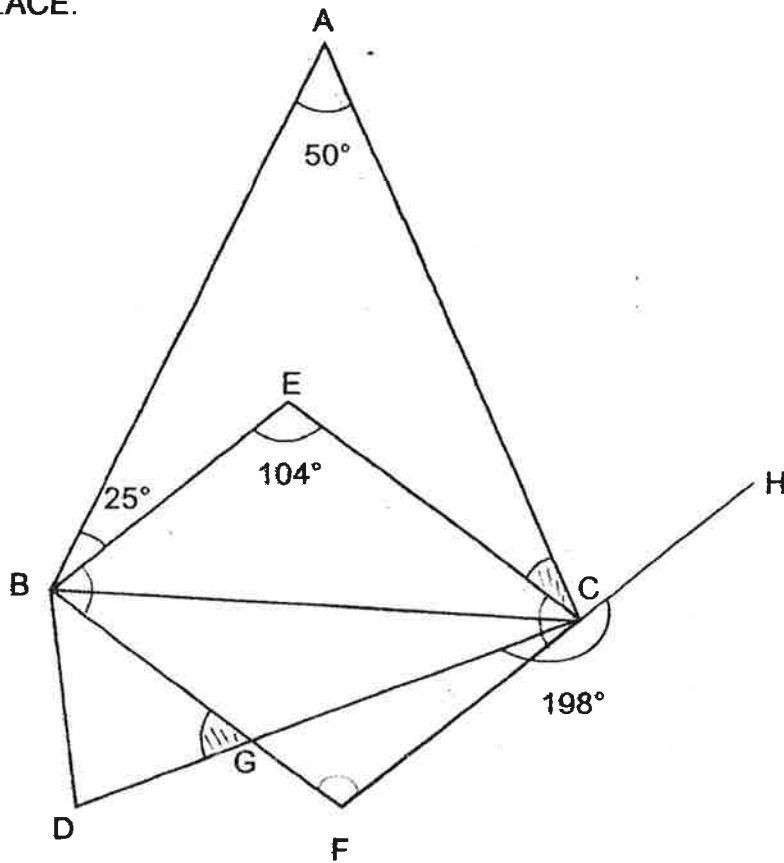

Ans: (a) \_\_\_\_\_ [2]

(b) \_\_\_\_\_ [2]

14. The mass of a container which is  $\frac{3}{5}$  filled with flour is 10.84 kg. When  $\frac{1}{3}$  of the flour is removed, the mass of the container and the remaining flour is 8.5 kg. Find the mass of the container.

Ans: \_\_\_\_\_ [4]

15. The figure is made up of a square of side 42cm, 2 identical big semicircles and 6 identical small semicircles.

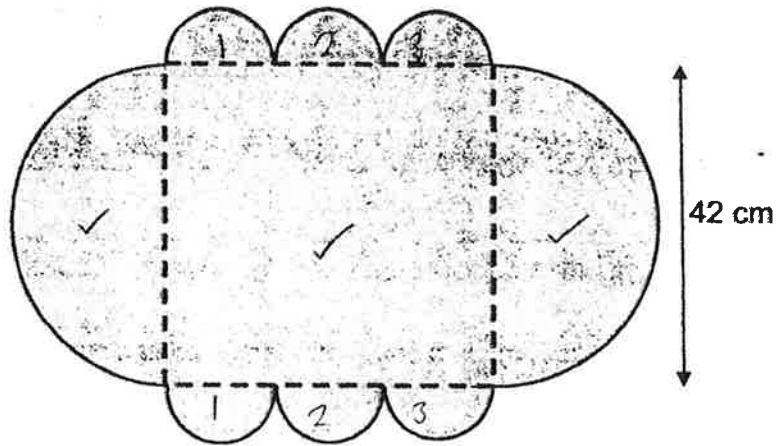

(a) What is the radius of each small semicircle?

(b) Find the area of the figure. Take  $\pi = \frac{22}{7}$ .

Ans: (a) \_\_\_\_\_ [1]

(b) \_\_\_\_\_ [3]

16. At Station A, the number of children was  $\frac{3}{5}$  of the number of adults on the MRT. At Station B,  $\frac{2}{9}$  of the adults and some children alighted from the MRT. The number of children became  $\frac{3}{7}$  of the number of adults. At Station C, 98 adults and 358 children boarded the MRT and there was an equal number of adults and children.

(a) How many passengers were there on the MRT after Station C?

(b) How many children alighted at Station B?

Ans: (a) \_\_\_\_\_ [4]

(b) \_\_\_\_\_ [1]

17. Mr Wong bought a number of red, blue and green balloons. The ratio of the number of red balloons to the number of blue balloons was 5 : 4 while the ratio of the number of blue balloons to the number of green balloons was 3 : 7. After bursting some green balloons and buying another 168 blue balloons, he found that there was a decrease of 25% in the total number of blue and green balloons. In the end, the number of red, blue and green balloons he had was 1440.

(a) How many balloons did Mr Wong have at first?

(b) How many green balloons were burst?

Ans: (a) \_\_\_\_\_ [3]

(b) \_\_\_\_\_ [2]

**End of Paper**  
**Please check your work carefully ☺**



## ANSWER KEY



**YEAR : 2019**  
**LEVEL : PRIMARY 6**  
**SCHOOL : RAFFLES PRIMARY SCHOOL**  
**SUBJECT : MATHEMATICS**  
**TERM : SA2**

### SECTION A

Q1	Q2	Q3	Q4	Q5	Q6	Q7	Q8
3	2	2	3	3	1	4	3
Q9	Q10	Q11	Q12	Q13	Q14	Q15	
4	3	1	4	3	4	1	

### SECTION B

Q16  $19/7$

Q17 0

Q18 1730

Q19 0495

Q20 1.901

Q21 49

Q22  $1\frac{1}{15}l$

Q23 \$60

Q24  $3p-5$

Q25 C

Q26 92cm

Q27 8m/s

Q28 14

Q29  $27^\circ$

Q30 288

### SECTION C

Q1  $7 : 3 \rightarrow 5 : 2$

$35 : 15 \rightarrow 35 : 14$

$1u = 46$

$14u = 644$

Q2  $\angle DAE = 180^\circ - 42^\circ \times 2$   
 $= 84^\circ$

$\angle CAB = 180^\circ - 34^\circ \times 2$   
 $= 112^\circ$

$\angle CAD = 112^\circ - 84^\circ = 28^\circ$

Q3 No Children  $\rightarrow 36 \div 2 = 18$

4 Children  $\rightarrow 60 - 33 - 18 = 9$

$\therefore 9/120 = 3/40$

Q4 Perimeter  $\rightarrow 24\text{cm}$

Area of Triangle  $\rightarrow \frac{1}{2} \times 8 \times 6 = 24\text{cm}^2$

Length of square  $\rightarrow 24 \div 4 = 6\text{cm}$

Area of square  $\rightarrow 6 \times 6 = 36\text{cm}^2$

$36 - 24 = 12 \therefore 12/24 = 50\% =$

Q5 (a) True

(b) Not possible to tell

(c) False

Q6  $t + t + t + s = 81.76$

$s + s + t = 38.56$

$6s + 3t = 115.68$

$5s = 115.68 - 81.76 = 33.92$

Square = 6.784

Q7  $698 - 358 = 340$

$340 \div 4 = 85$

$258 - 85 = 173$

Q8  $\angle FGC = 180^\circ - 100^\circ = 80^\circ$

$\angle ECD = 360^\circ - 90^\circ - 230^\circ = 40^\circ$

$\angle ECB = 90^\circ - 40^\circ = 50^\circ$

Q9  $d = 18 \times 2 = 36$   
 Perimeter  
 $\frac{1}{6} \times 3.14 \times 36 = 18.84$   
 $18.84 \times 3 = 56.52$   
 $18 \times 6 = 108$   
 $108 + 56.52 = 164.52$

Q10 Valerie : Isabelle  
 $7 : 5 \rightarrow 8.75 : 3.75$   
 $750 = 8.75u + 3.75u$   
 $750 = 12.5u$   
 $u = 750 \div 12.5 = 60$   
 $7u = 60 \times 7 = 420$

Q11 (a) Hot dogs and Chicken pies  
 (b)  $48 + 75 \times 2 + 100 = 298$   
 $(48 \div 298) \times 100\% \approx 16.11\%$

Q12 (a)  $0.55 \times 50 = \$27.5$   
 (b)  $129.42 - 27.50 = 101.92$   
 $101.92 - (0.72 \times 100)$   
 $= 29.92$   
 $89.92 \div 0.88 = 34$   
 $34 + 100 + 50 = 184$

Q13 (a)  $\angle GCF = 198^\circ - 180^\circ = 18^\circ$   
 $\angle DGB = 180^\circ - 18^\circ - 104^\circ = 58^\circ$   
 (b)  $\angle EBF = 180^\circ - 104^\circ = 76^\circ$   
 $\angle BEC = 360^\circ - 104^\circ = 256^\circ$   
 $\angle ACE = 360^\circ - 256^\circ - 50^\circ - 25^\circ$   
 $= 29^\circ$

Q14



$\frac{3}{5} \times \frac{2}{3} = \frac{2}{5}$   
 $3u + c = 10.84$   
 $2u + c = 8.5$   
 $u = 10.84 - 8.5 = 2.34$   
 $2u = 2.34 \times 2 = 4.68$   
 $C \rightarrow 8.5 - 4.68 = 3.82$

Q15 (a)  $3d = 42, d = 14, r = 7$   
 (b) Area of big Semicircle  
 $\frac{22}{7} \times 21 \times 21 = 1386$

Area of small Semicircle  
 $\frac{22}{7} \times 7 \times 7 \times 3 = 462$

Area of Square  
 $42 \times 42 = 1764$   
 Total  $\rightarrow 1764 + 462 + 1386 = 3612$

Q16 Children : Adults  
 $3 \times 9 : 5 \times 9$

Station A  $27 : 45$   
 Station B  $-12 : -10$   
 Station C  $15 : 35$   
 $15u + 358 = 35u - 98$   
 $358 - 98 = 35u - 15u$   
 $260 = 20u$   
 $u = 13$

(a)  $50u = 650$   
 $650 + 358 + 98 = 1106$   
 (b)  $12u + 10u = 22u$   
 $12u = 12 \times 13 = 156$

Q17 Red : Blue : Green

$15u : 12u : 28u$   
 $15u : (12+18)u$   
 $1440 \rightarrow 15u + 30u$   
 $u = 1440 \div 45 = 32$

(a) At first,  $55u$   
 $55 \times 32 = 1760$   
 (b)  $12u \rightarrow 32 \times 12 = 384$   
 $384 + 168 = 552$   
 $30u \rightarrow 32 \times 30 = 960$   
 $28u \rightarrow 32 \times 28 = 896$   
 $960 - 552 = 408$   
 $896 - 408 = 488$

